

Do Not Run Pumps Dry. Must have a flooded suction environment.

Note: Testing performed in a controlled laboratory environment. Actual performance may vary (+) or (-) 10% from the information shown.



Performance, Electrical Data

24 VDC							
Flow (GPM)	Flow (L)	Ttl. Hd. (Ft)	Ttl. Hd. (PSI)	Ttl. Hd. (M)	Watts	Volts	Amps
7.73	29.27	10.57	4.58	3.22	57.84	24.01	2.41
7.30	27.65	11.51	4.99	3.51	57.52	24.01	2.40
6.79	25.72	12.23	5.30	3.73	56.82	24.01	2.37
6.28	23.77	14.97	6.49	4.56	55.88	24.01	2.33
5.98	22.65	15.61	6.77	4.76	55.52	24.01	2.31
4.81	18.20	18.14	7.86	5.53	52.92	24.01	2.20
4.37	16.56	19.65	8.52	5.99	51.31	24.01	2.14
3.83	14.49	20.54	8.91	6.26	49.60	24.01	2.07
2.91	11.00	23.02	9.98	7.02	47.12	24.01	1.96
2.34	8.87	23.36	10.13	7.12	44.95	24.01	1.87
1.86	7.03	23.70	10.28	7.23	43.33	24.01	1.80
1.38	5.23	24.36	10.56	7.43	41.86	24.01	1.74
0.73	2.78	27.39	11.88	8.35	39.18	24.01	1.63
0.00	0.00	29.31	12.70	8.93	36.71	24.01	1.53

21 VDC							
Flow (GPM)	Flow (L)	Ttl. Hd. (Ft)	Ttl. Hd. (PSI)	Ttl. Hd. (M)	Watts	Volts	Amps
6.94	26.28	8.96	3.88	2.73	42.23	21.01	2.01
6.48	24.54	9.81	4.25	2.99	41.99	21.01	2.00
5.90	22.32	11.24	4.87	3.43	41.21	21.01	1.96
4.31	16.30	15.28	6.63	4.66	38.31	21.01	1.82
3.74	14.16	15.67	6.79	4.78	37.03	21.01	1.76
3.32	12.56	16.94	7.34	5.16	36.21	21.01	1.72
2.86	10.83	17.80	7.72	5.43	35.00	21.01	1.67
2.32	8.80	19.18	8.31	5.85	33.28	21.01	1.58
1.81	6.86	19.00	8.24	5.79	31.95	21.01	1.52
1.27	4.82	20.19	8.75	6.16	30.62	21.01	1.46
0.76	2.87	22.03	9.55	6.72	28.71	21.01	1.37
0.00	0.00	22.80	9.88	6.95	26.75	21.01	1.27

18 VDC							
Flow (GPM)	Flow (L)	Ttl. Hd. (Ft)	Ttl. Hd. (PSI)	Ttl. Hd. (M)	Watts	Volts	Amps
6.17	23.35	6.83	2.96	2.08	29.34	18.00	1.63
3.79	14.33	11.91	5.16	3.63	26.58	18.00	1.48
3.16	11.98	12.94	5.61	3.94	25.59	18.00	1.42
2.74	10.39	13.69	5.94	4.17	24.90	18.00	1.38
2.28	8.65	14.70	6.37	4.48	23.84	18.00	1.32
1.73	6.56	15.28	6.62	4.66	22.43	18.00	1.25
1.29	4.88	15.92	6.90	4.85	21.36	18.00	1.19
0.75	2.85	16.37	7.10	4.99	20.44	18.00	1.14
0.00	0.00	17.31	7.50	5.28	18.12	18.00	1.01

15 VDC							
Flow (GPM)	Flow (L)	Ttl. Hd. (Ft)	Ttl. Hd. (PSI)	Ttl. Hd. (M)	Watts	Volts	Amps
5.24	19.84	4.89	2.12	1.49	19.19	15.00	1.28
3.10	11.73	9.03	3.92	2.75	17.40	15.00	1.16
2.68	10.13	9.52	4.13	2.90	16.78	15.00	1.12
2.14	8.10	10.33	4.48	3.15	15.98	15.00	1.07
1.64	6.20	10.82	4.69	3.30	14.96	15.00	1.00
1.14	4.33	11.42	4.95	3.48	14.00	15.00	0.93
0.74	2.81	11.63	5.04	3.54	13.35	15.00	0.89
0.00	0.00	12.63	5.48	3.85	11.86	15.00	0.79

12 VDC							
Flow (GPM)	Flow (L)	Ttl. Hd. (Ft)	Ttl. Hd. (PSI)	Ttl. Hd. (M)	Watts	Volts	Amps
4.35	16.48	3.47	1.51	1.06	11.61	12.00	0.97
2.55	9.66	6.18	2.68	1.89	10.63	12.00	0.89
2.10	7.96	6.70	2.90	2.04	10.12	12.00	0.84
1.62	6.14	7.41	3.21	2.26	9.59	12.00	0.80
1.11	4.22	7.25	3.14	2.21	8.88	12.00	0.74
0.74	2.81	7.77	3.37	2.37	8.50	12.00	0.71
0.00	0.00	8.60	3.73	2.62	7.08	12.00	0.59

9 VDC							
Flow (GPM)	Flow (L)	Ttl. Hd. (Ft)	Ttl. Hd. (PSI)	Ttl. Hd. (M)	Watts	Volts	Amps
1.93	7.31	3.57	1.55	1.09	5.80	9.00	0.64
1.53	5.80	4.00	1.73	1.22	5.53	9.00	0.61
1.00	3.77	4.14	1.79	1.26	5.12	9.00	0.57
0.75	2.84	4.40	1.91	1.34	4.89	9.00	0.54
0.00	0.00	5.17	2.24	1.58	4.10	9.00	0.46

Note: Testing performed in a controlled laboratory environment. Actual performance may vary (+) or (-) 10% from the information shown.



Electrical Specifications / Wiring Diagram

60W/24V INTG3		
Wire Colors		
Power (V+/V-)	Red/Black	
Speed	N/A	
	Tach	N/A
Operating Voltage Range	9-24 V	
Current at Nominal Voltage	2.41 A (at 24 V)	
Maximum Wattage	60 W	
Speed Control (DC Input)		Note: The negative of the control signal must be referenced to the negative of the pump supply. Input impedance of speed control is typically 100K Ohms
OPTIONAL	PWM	
	Duty Cycle	N/A
	Frequency	N/A
	Voltage Range	N/A
	ANALOG	
Voltage Range (Nominal)	N/A	Note: this varies with different wattage limits; pumps with lower limits may reach max performance before 4V.
Voltage Range (Actual)	N/A	
Tach Signal (DC Output)		Note: The tach signal is a square wave; slew rate 40 micro sec/5 volt. Push/pull output. 6 pulses/revolution
OPTIONAL	Frequency	N/A
	Voltage Range	N/A
	RPM Calculation	N/A
Start-Up Time	< 3 seconds	Note: Pump may take somewhat longer depending on the power supply
Max Inrush Current		
At Start-Up	59 A	
50 to 100% Performance	N/A	
Recommended Fuse	5 A (fast-acting)	

General Specifications, Wetted Materials

Do Not Run Pumps Dry. Pumps must be in a continuous flooded suction environment.

General Specifications	
In-House Stator	50 Turns, 25 AWG
Motor Magnets	Segmented Neodymium
Suction Port	3/4" MHB
Discharge Port	3/4" MHB
Mounting Bracket	PPS material
Max Fluid Temp	149°F (65°C)
Max System Pressure	75 PSI
Weight	Approximately .8 LBS, 390 Grams
Product Test Report	PTR23842

Wetted Materials	
Pump Body	PPS
Pump Adapter	PPS
Impeller	PPS
Impeller Shaft	Ceramic
Bearing	BMC
Static O-Ring	EPDM

Available agency approvals

Contact GRI for **UL, NSF** options.

UL778: Motor-operated Water Pumps

NSF 61: Potable Water

NSF 372: Lead Content

RoHS / REACH

Many GRI pumps are RoHS & REACH compliant. For declarations by specific model numbers, please contact GRI.

INTG3-119 N Drawing & Dimensions

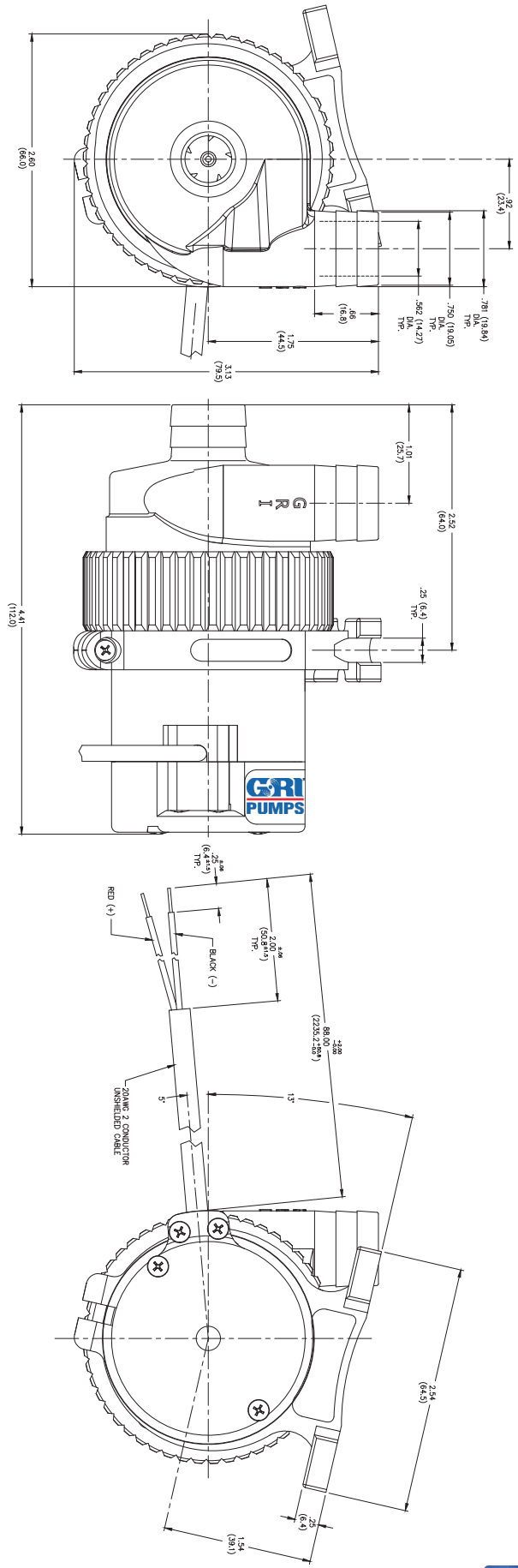



!! PLEASE READ in order to maximize the efficiency and life of your GRI pump !!

The following describes installation requirements and the possible damage which could result from failure to follow these requirements.

PRIOR TO STARTUP:

Connecting Power: Prior to connecting power, refer to the Electrical Specifications page for important electrical details and wiring diagram. Do not power on the pump without connection to a fluid supply and with fluid contained within the pump's cavity.

DO NOT RUN DRY: Never operate the pump without fluid in the pump's cavity. Running the pump dry will destroy the pump.

Flooded Suction: It is important that the pump's cavity be filled with fluid prior to startup and during pump operation. To accomplish this, the pump must be positioned so that the fluid supply is above the pump's suction port. This is known as Flooded Suction. Operating the pump without an adequate supply of fluid and/or dry running the pump will dramatically decrease the life of or destroy the pump.

Supply line: It is recommended that at least 6.0" (152.4 mm) of straight supply line is connected to the suction port of the pump prior to any turns, angles, or elbows in the plumbing. Not having an efficient length of straight supply line may cause restricted flow, starved suction, and cavitation which will dramatically decrease the life of the pump.

Flexible or weak walled tubing should be avoided. Flexible and weak walled tubing may collapse due to the suction force of the pump. Tubing collapse will result in restricted or zero fluid to the pump. Operating the pump without an adequate supply of fluid and/or dry running the pump will dramatically decrease the life of or destroy the pump.

Pump Positioning: It is recommended that the pump's suction port be positioned in a horizontal or facing up position. Installing the pump with the suction port facing down is not recommended. Operating the pump with the suction port facing down can cause overworking of the pump due to an inadequate supply of fluid (starved suction).

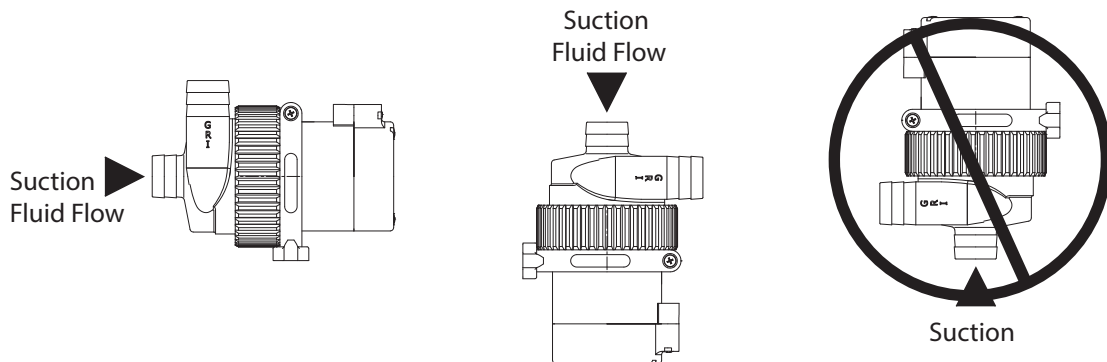

Pump Body Rotation: It is highly recommended to not loosen and/or turn/reposition the pump body. Doing so can cause the pump to leak. Special setup and procedures are used in GRI's manufacturing process to attach and position the pump body. Per OEM request, GRI can turn/reposition the pump body prior to shipping. Contact your GRI representative for more information.

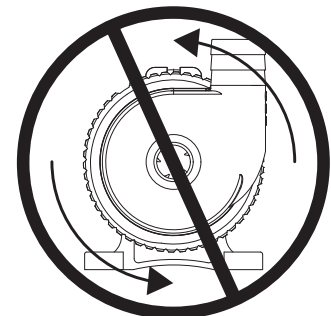

Contact your GRI representative with questions regarding this information sheet.